

RESERVDELAR

SC OFC 231

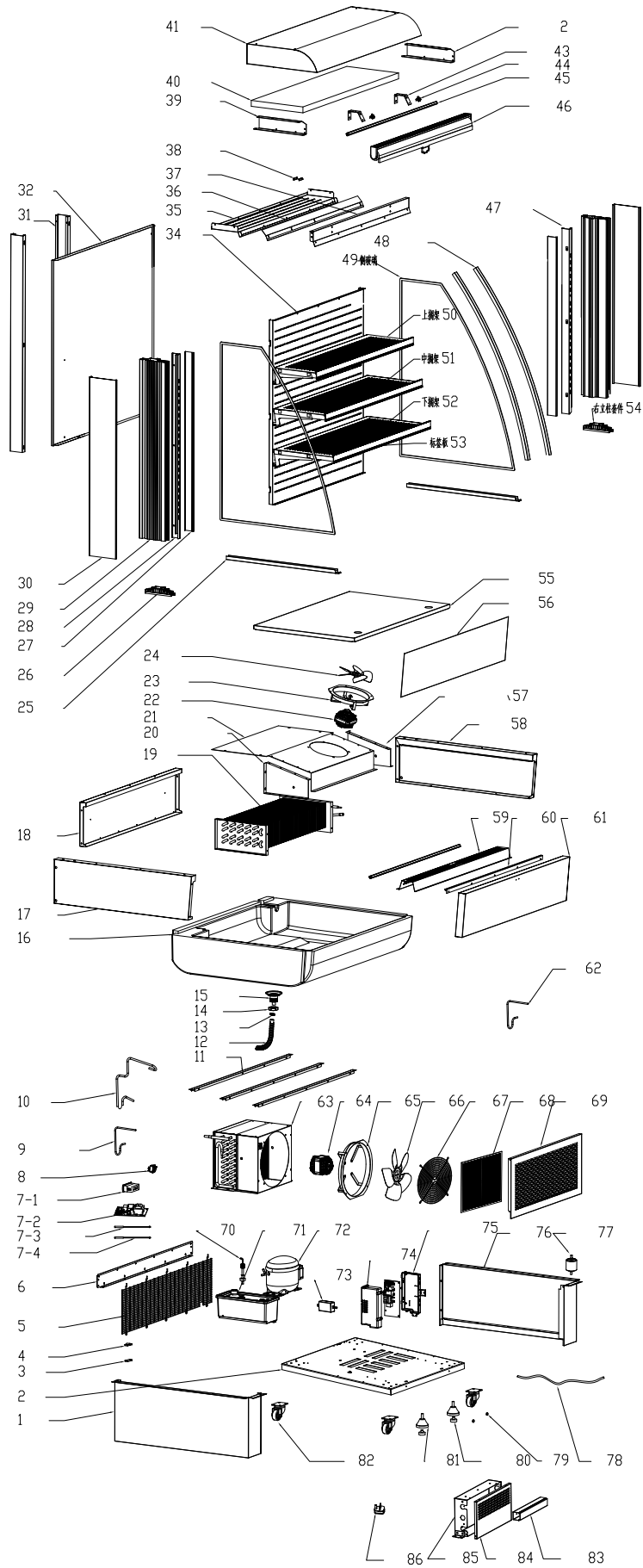

Pos.No.	Part No	Description
1	RES-15696	Left panel of base
2	RES-15695	Fixed plate
3	RES-15694	Wire clip holder
4	RES-15693	Wire clip cover
5	RES-15692	Back cover of base
6	RES-15691	Crossbar of base
7	RES-18927	Mainboard complete
8	RES-21840	Display
9	RES-21856	Mainboard
10	RES-21839	Overheating probe
11	RES-18973	Temp. probe
12	RES-15689	Switch
13	RES-15688	Connection pipe1
14	RES-16170	Connection pipe2
15	RES-15686	Barrier strip
16	RES-21876	Drain pipe
17	RES-15684	Circlip
18	RES-15683	Nut
19	RES-15682	Pipe joint
20	RES-15681	Evaporator holder
21	RES-15680	Left board of cabinet
22	RES-15679	Back board of cabinet
23	RES-15678	Evaporator
24	RES-15677	Left board of Evaporator cover
25	RES-15676	Evaporator cover
26	RES-15635	Fan Motor for evaporator
27	RES-15675	Flange
28	RES-15608	Fan blade of condenser
29	RES-15674	Bottom strip of side glass
30	RES-15673	Cover of Left pillar
31	RES-15672	Inner decorated strip
32	RES-15671	Left support pillar of shelf
34	RES-15670	Side pillar of cabinet
35	RES-15669	Outer decorated strip
36	RES-15668	Back barrier strip
37	RES-21877	Back cover of cabinet
38	RES-15665	Ventilated board
39	RES-15664	Ceiling board of cabinet
40	RES-15663	Air deflector
41	RES-15662	Board ahead curtain
42	RES-15661	Air deflector joint
43	RES-21863	Upper left rail
44	RES-15659	Top foam
45	RES-15658	Top cover
46	RES-21865	Upper right rail
47	RES-21878	Night curtain bracket
48	RES-15655	LED strip clip
49	RES-21879	LED strip
50	RES-21880	Night curtain
51	RES-15652	Right support pillar of shelf
52	RES-21881	Decorated strip
53	RES-15650	Side glass
54	RES-15649	Upper shelf
55	RES-15648	Middle shelf
56	RES-15647	Bottom shelf
57	RES-21882	Price tag holder
58	RES-15645	Cover of right pillar
59	RES-15644	Bottom board of cabinet
60	RES-15643	Glass deflector
61	RES-15642	Right board of Evaporator cover
62	RES-15641	Right board of cabinet
63	RES-15640	Air inlet cover
64	RES-15639	Barrier strip of glass
65	RES-15638	Front board of cabinet
66	RES-15637	Connection pipe3
67	RES-15636	Condenser
68	RES-15635	Fan Motor for evaporator
69	RES-15634	Flange
70	RES-15633	Fan blade
71	RES-15632	Motor mesh
72	RES-15631	Air filter
73	RES-15630	Ventilated board of base
74	RES-21872	Water level detector
75	RES-21873	Water receiver
76	RES-21247	Compressor R290
77	RES-21701	Led Power Drive
78	RES-15624	Circuit board box
79	RES-21875	Cover of circuit board box
80	RES-15621	Right panel of base
81	RES-15620	Dry filter
82	RES-15619	Power cord
83	RES-15618	Magnet
84	RES-15615	Fixed stopper
85	RES-15617	Feet
86	RES-15616	Castor
87	RES-18921	PVC trucking
88	RES-21883	Cover of terminal box
89	RES-21884	Terminal box